

**WALL MOUNTED
SWITCH MANUAL**

Wall mounted switch

Adding to Z-Wave™ Network.....	2
Association.....	5
Configuration.....	6
Specification.....	8
Switch Size.....	9
Switch Type.....	10

Two channel wall mounted switch

Adding to Z-Wave™ Network.....	12
Association.....	15
Configuration.....	16
Specification.....	18
Switch Size.....	19
Switch Type.....	19

TC series touch screen switch

Adding to Z-Wave™ Network.....	21
Specification.....	23
Switch Size	24
Switch Type.....	24

Wall mounted switch

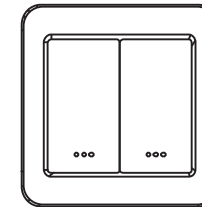

Note: This switch must be “Included in the Network” only where it will be permanently installed. The proper operation of this node in the mesh network is dependent on knowing its location with respect to other nodes. You cannot “test bench” configure this switch then install.

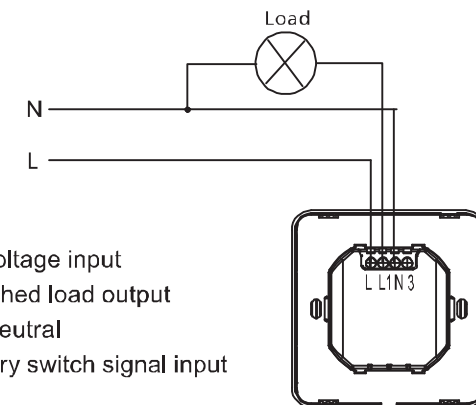

The wall mounted 3-way switch is a component of the lighting control system. This wall mounted switch is designed to work with other Z-Wave enabled devices. Z-Wave nodes of other types can be added to the system and will also act as repeaters if they support this function of repeating the signal received to other modules in the system. As part of a Z-Wave network, this switch will also act as a wireless repeater to insure that commands intended for another device in the network are received. This is useful when the device would otherwise be out of the radio range of the wireless controller. There are no field repairable assemblies on this unit. If service was need,the unit must be returned where purchased.

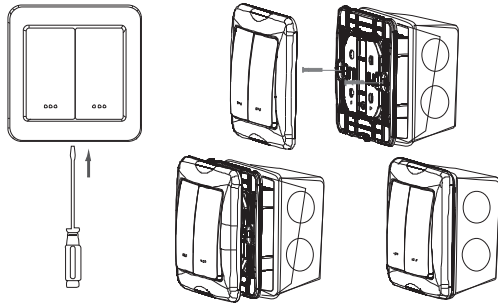

Adding to Z-Wave™ Network

In the front casing, there is an On/Off button with LED indicator which is used to toggles witch on and off or carry out inclusion, exclusion, reset or association. When first power is applied, its LED flashes on and off alternately and repeatedly at 1-second intervals. It implies that it has not been assigned a node ID and cannot work with Z-Wave enabled devices. The table below lists an operation summary of basic Z-Wave function. Please refer to the instructions for your Z-Wave™ certificated primary controller to access the setup function, and to include/exclude/associate devices.

Function	Description	LED Indication
No node ID	The Z-Wave controller does not allocate a node ID to the Switch	1-second on, 1-second off
Add	1. Have Z-Wave controller entered inclusion mode.	Press on, for off Press off, for on
	2. Pressing On/Off button three times within 1.5 seconds will enter inclusion mode.	
Remove	1. Have Z-Wave controller entered inclusion mode.	Press on, for off Press off, for on
	2. Pressing On/Off button three times within 1.5 seconds will enter exclusion mode.	
	Node ID has been excluded.	1-second on, 1-second off
Reset	1. Pressing On/Off button three times within 1.5 seconds will enter inclusion mode.	Press on, for on Press off, for off
	2. Within 5 second, press On/Off button again for 1 seconds until LED is off	
	3. IDs are excluded.	
Association	1. Have Z-Wave Controller entered association mode. Or Pressing On/Off button three times within 1.5 seconds will enter association mode	Press on, for on Press off, for off
	2. There are four groups for the switch (it can associate max five devices).	

- ※ Including a node ID allocated by Z-Wave controller means Add. Excluding anode ID allocated by Z-Wave controller means Remove.
- ※ Failed or success in including/excluding the node ID can be viewed from the Z-Wave controller.
- ※ Association: it can be associated by Z-Wave devices with association
- ※ Use the "Reset" procedure only in the event that the network primary controller is missing or otherwise inoperable



Basic Operation (Local Control)

The left switch on the switch allows the user to:

- The on or off the attached load.
- Include or exclude the module from the Z-Wave system.
- Control other Z-Wave enabled devices.

The right switch on the switch allows the user to:

- Control other Z-Wave enable devices

Also, when a controller prompts you to "Send Node ID" or to "Press Button on Unit", quickly tap the switch on or off three times to satisfy those instructions.

- Tapping top of left switch turns the load attached on.
- Tapping bottom of left switch turns the load attached off.
- Pressing and holding the left switch does not effect the load attached but will allow dimming and brightening of Z-Wave dimmers if associated.

Caution: When dimmed at the lowest setting, even though the load looks like its off, it still has power. Tap bottom of switch to turn off completely. It is best to turn off the power at the circuit breaker to service the load.

Note: Upon restoration of power after a power loss, the switch returns to previous known state.

LED Indication

The LED on the switch will turn on when the load attached is off, to act as a night light. However, the LED can be user configured to turn on when the load attached is on the switch will flicker its LED when it is transmitting to any of its 4 groups. This can be changed if desired. See "LED transmission indication"

Remote Control

The switch will respond to BASIC and BINARY commands that are part of the Z-Wave system. refer to your controller's instructions as to whether your controller can transmit those commands.

Advance operation all on/all off

The switch support the all on/all off commands. The switch can be set to respond to all on and all off commands 4 different ways. Refer to your controller for information on how to set the switch to operate in the manner you desire. Some controllers may be only able to set certain settings of all on/all off response. The 4 different ways the switch can be setup to respond to all on and all off

Association

The switch supports the association command.

The switch can be set to control other Z-Wave devices. Those devices must be installed in their permanent location.

You can turn on and off, and even dim other Z-Wave devices once they are "associated" into 1 of 4 group s within the switch.

Each group is turned on or off (or dimmed) by tapping or holding the switch a differing amount of times.

Group 1 Control: If you associate a Z-Wave device into Group 1, you can turn that device ON and OFF by tapping the top or bottom of the left switch You can brighten or dim devices by pushing and holding the top of the left switch Dim by pushing and holding the bottom of the left switch. The load attached to the switch is not affected. The LED on the left switch will indicate the status of Group 1. Group 2 will be polled at a specific interval and the LED on the left switch will indicate the status of Group 1. The polling interval can be configured. The Group1name is lifeline(Profile MSB=0x00,Profile LSB=0x01).

Group 2 Control: If you associate a Z-Wave device into Group 2, you can turn that device ON and OFF by tapping the top or bottom of the right switch You can brighten or dim devices by pushing and holding the top of the right switch Dim by pushing and holding the bottom of the right switch. The load attached to the switch is not affected. The LED on the right switch will indicate the status of Group 2. Group 2 will be polled at a specific interval and the LED on the right switch will indicate the status of Group 2. The polling interval can be configured. The Group2 name is On/Off Dimmer 1(Profile MSB=0x20, Profile LSB=0x01). This group can't be supported to single panel switch .

Group 3 Control: If you associate a Z-Wave device into Group 3, you can turn that device ON or OFF by tapping the top or bottom of the right switch twice. You can brighten or dim devices by tapping the switch once then push and hold the top or bottom of the right switch. The load attached to the switch is not affected. The Group3 name is On Off Dimmer 2 (Profile MSB=0x20, Profile LSB=0x02). This group can't be supported to single panel switch

Group 4 Control: If you associate a Z-Wave device into Group 4, that device will be commanded to turn on or off when the switch is commanded to turn on or off. **Caution:** The switch will not transmit to Z-Wave devices in Group 4 if it is already in the state that the Z-Wave command commanded it to. You can associate up to 5 Z-Wave devices into each of these groups. For instructions on how to "associate" a Z-Wave device into one of these groups, refer to your wireless controller instructions. (If you are using the z-wave controller, refer to the setup menu, association section). A note about dimming, if you combine Z-Wave enabled dimmers and other types of Z-Wave devices in a group, place a Z-Wave enabled dimmer into the empty group first to ensure that the dimming operates correctly. The Group4 name is wireless. (Profile MSB=0x20, Profile LSB=0x03)

Configuration

Configuration Parameter	Function	Size(Byte)	Value	Default
1	Night light	1	0-1	1
2	Memory function	1	0-1	1
3	Invert switch	1	0-1	0
4	LED Transmission indication	1	0-2	1
5	Suspend Group4	1	0-1	0

Night light

- Parameter NO:1
- Length: 1 Byte

- Valid values=0 or 1 (default value is 1)

The LED on the switch will by default, turn ON when the load attached is turn OFF. To make the LED turn ON when the load attached is turn ON instead, set parameter 1 to a value of 1.

Memory function

Parameter NO:2

- Length: 1 Byte
- Valid values=0 or 1 (default value is 1)

Stated in the above form, switch by default value is 1, when the value is 0, switch memory function not open; when the value is 1, open switch memory function.

Invert switch

- Parameter NO:3
- Length: 1 Byte
- Valid values=0 or 1 (default value is 0)

To change the top of the switch to OFF and the bottom of the switch ON, set parameter 3 to 1.

Note: if you invert the switches and also install the product upside down, remember the load will now be controlled by the right, not the left switch.

LED transmission indication

- Parameter NO:4
- Length: 1 Byte
- Valid values = 0,1,2,(default value is 1)

The switch will flicker its LED when it is transmitting to any of its 4 groups. This flickering can be set to not flicker at all (set to 0), to flicker the entire time it is transmitting (set to 2), or to flicker for only 1 second when it begins transmitting (set to 1). By default, the switch is set to flicker for only 1 second. Each configuration parameter can be set to its default setting by setting the default bit in the configuration set command. see your controller's instructions on how to do this (and if it supports it). All configuration commands will be reset to their default state when the switch is reset from the Z-Wave system.



Suspend group 4

- Parameter NO:5
- Length:1 Byte
- Valid values = 0 or 1(default value is 0)

You may wish to disable transmitting commands to Z-Wave devices that are in Group 4 without “disassociating” those devices from the group. Setting parameter 5 to the value of 1 will stop the switch from transmitting to devices that are “associated” into Group 4.

Power level

The switch supports the power level command.

The power level command allows controllers to set and get the RF transmit power level of a node and test specific links between nodes with specific RF transmit power. Refer to your controller’s instruction, if it supports this command, for more information .This command is typically used by professional installers.

Specification

Type	Support the dimming	Support Group 2 and Group 3	Maximum Load
TZ35S	YES	NO	300W
TZ35D	YES	YES	300W
TZ36S	NO	NO	1380W
TZ36D	NO	YES	1380W
TZ55S	YES	NO	300W
TZ55D	YES	YES	300W
TZ56S	NO	NO	1380W
TZ56D	NO	YES	1380W

Operating Voltage	AC230V 50Hz
Range	Minimum 40m in door 70m outdoor line of sight
Operating Temperature	0°C~40°C
Frequency Range	868.4MHz(EU),869MHz(RU)

Specifications are subject to change and improvement without notice.



Switch Size(mm)

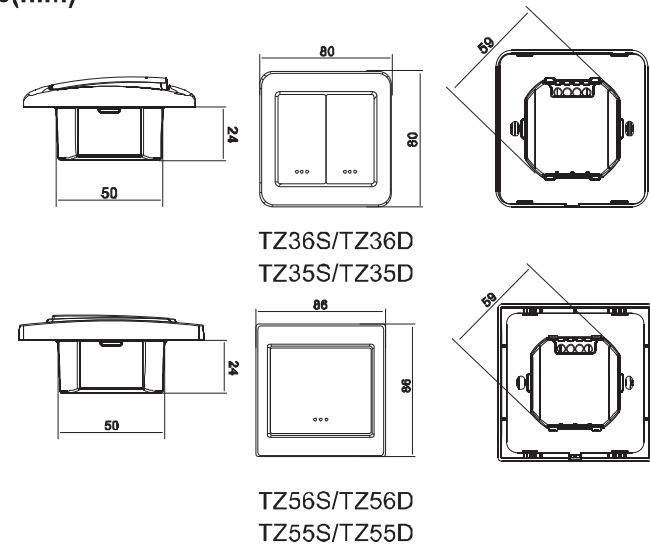

Switch Type



TZ36S
TZ35S

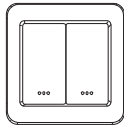

TZ36D
TZ35D

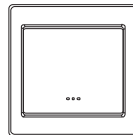

TZ56S
TZ55S

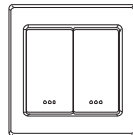

TZ56D
TZ55D



TZ35/TZ36/TZ55/TZ56-V1.1-2017.4.18

Two channel wall mounted switch

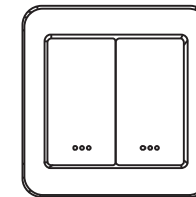

Note: This switch must be “Included in the Network” where it will be permanently installed. The proper operation of this node in the mesh network is dependent on knowing its location with respect to other nodes. You can not “test bench” configure this switch then install.

Wall mounted switch

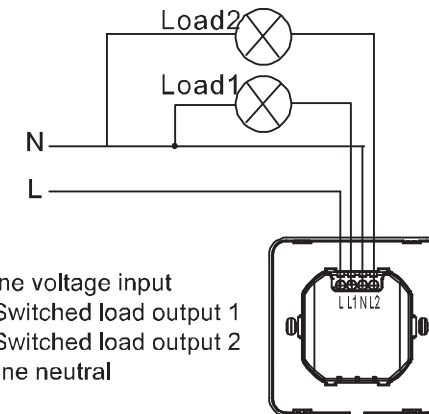

The wall mounted switch is a component of the lighting control system. This wall mounted switch is designed to work with other Z-Wave enabled devices. Z-Wave nodes of other types can be added to the system and act as repeaters if they support this function of repeating the signal received to other modules in the system. As part of a Z-Wave network, this switch will also act as a wireless repeater to insure that commands intended for another device in the network are received. This is useful when the device would otherwise be out of the radio range of the wireless controller. There are no field repairable assemblies on this unit. If service was needed ,the unit must be returned where purchased.

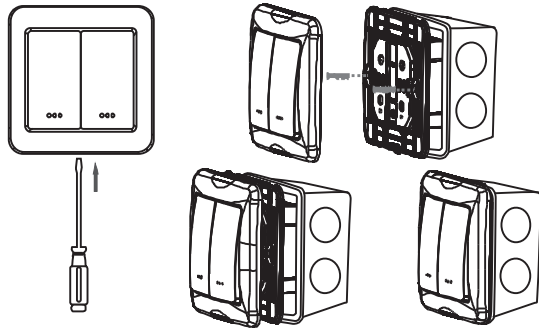

Adding to Z-Wave™ Network

In the front casing, there is an On/Off button with LED indicator which is used to toggles witch on and off or carry out inclusion, exclusion, reset or association. When first power is applied, its LED flashes on and off alternately and repeatedly at 1-second intervals. It implies that it has not been assigned a node ID and cannot work with Z-Wave enabled devices. The table below lists an operation summary of basic Z-Wave function. Please refer to the instructions for your Z-Wave™ certificated primary controller to access the Setup function, and to include/exclude/associate devices.

Function	Description	LED Indication
No node ID	The Z-Wave controller does not allocate a node ID to the Switch	1-second on, 1-second off
Add	1. Have Z-Wave controller entered inclusion mode.	Press on, for off Press off, for on
	2. Pressing On/Off button three times within 1.5 seconds will enter inclusion mode.	
Remove	1. Have Z-Wave controller entered inclusion mode.	Press on, for off Press off, for on
	2. Pressing On/Off button three times within 1.5 seconds will enter exclusion mode.	
	Node ID has been excluded.	1-second on, 1-second off
Reset	1. Pressing On/Off button three times within 1.5 seconds will enter inclusion mode.	Press on, for on Press off, for off
	2. Within 5 second, press On/Off button again for 1 seconds until LED is off	
	3. IDs are excluded.	
Association	1. Have Z-Wave Controller entered association mode. Or Pressing On/Off button three times within 1.5 seconds will enter association mode	Press on, for on Press off, for off
	2. There are four groups for the switch (it can associate max five devices).	
※ Including a node ID allocated by Z-Wave controller means Add. Excluding anode ID allocated by Z-Wave controller means Remove. ※ Failed or success in including/excluding the node ID can be viewed from the Z-Wave controller. ※ Association: it can be associated by Z-Wave devices with association ※ Use the "Reset" procedure only in the event that the network primary controller is missing or otherwise inoperable		

Basic Operation (Local Control)

The switch allows the user to:

- The ON or OFF the attached load.
- Include or exclude the module from the Z-Wave system.
- Control other Z-Wave enabled devices.

Also, when a controller prompts you to "Send Node ID" or to "Press Button on Unit", quickly tap the switch On or OFF three times to satisfy those instructions.

- Tapping top of left switch turns the load1 attached ON.
- Tapping bottom of left switch turns the load1 attached OFF.
- Tapping top of right switch turns the load2 attached ON.
- Tapping bottom of right switch turns the load2 attached OFF.

Caution: When dimmed at the lowest setting, even though the load looks like its off, it still has power. Tap bottom of switch to turn off completely. It is best to turn off the power at the circuit breaker to service the load.

Note: Upon restoration of power after a power loss, the switch returns to previous known state.

LED Indication

The LED on the switch will turn on when the load attached is off, to act as a night light. However, the LED can be user configured to turn on when the load attached is on the switch will flicker its LED when it is transmitting to any of its 4 groups. This can be changed if desired. See "LED transmission indication"

Remote control

The switch will respond to BASIC and BINARY commands that are part of the Z-Wave system. Refer to your controller's instructions as to whether your controller can transmit those commands.

Advance operation all on/all off

The switch support the all on/all off commands. The switch can be set to respond to all on and all off commands 4 different ways. Refer to your controller for information on how

to set the switch to operate in the manner you desire. Some controllers may be only able to set certain settings of all on/all off response. The 4 different ways the switch can be setup to respond to all on and all off

Association

The switch supports the association command.

The switch can be set to control other Z-Wave devices. Those devices must be installed in their permanent location.

You can turn on and off, and even dim other Z-Wave devices once they are "associated" into 1 of 4 groups within the switch.

Each group is turned on or off (or dimmed) by tapping or holding the switch a differing amount of times.

Group 1 Control: If you associate a Z-Wave device into Group 1, you can turn that device ON and OFF by tapping the top or bottom of the right switch, You can brighten or dim devices by pushing and holding the top of the right switch Dim by pushing and holding the bottom of the right switch. The load attached to the switch is not affected. The LED on the right switch will indicate the status of Group 1. Group 1 will be polled at a specific interval and the LED on the right switch will indicate the status of Group 1. The polling interval can be configured. The Group1 name is lifeline(Profile MSB=0x00,Profile LSB=0x01).

Group 2 Control: If you associate a Z-Wave device into Group 2, you can turn that device ON or OFF by tapping the top or bottom of the left switch twice. You can brighten or dim devices by tapping the switch once then push and hold the top or bottom of the left switch. The load attached to the switch is not affected. The LED on the left switch will indicate the status of Group 2. Group 2 will be polled at a specific interval and the LED on the left switch will indicate the status of Group 2. The polling interval can be configured. The Group2 name is On/Off Dimmer 1(Profile MSB=0x20,Profile LSB=0x01).

Group 3 Control: If you associate a Z-Wave device into Group 3, you can turn that device ON or OFF by tapping the top or bottom of the right switch twice. You can brighten or dim devices by tapping the switch once then push and hold the top or bottom of the

right switch. The load attached to the switch is not affected. The Group3 name is on off dimmer 2 (Profile MSB=0x20,Profile LSB=0x02).

Group 4 Control: If you associate a Z-Wave device into Group 4, that device will be commanded to turn on or off when the switch is commanded to turn on or off. Caution: The switch will not transmit to Z-Wave devices in Group 4 if it is already in the state that the Z-Wave command commanded it to. You can associate up to 5 Z-Wave devices into each of these groups. For instructions on how to “associate” a Z-Wave device into one of these groups, refer to your wireless controller instructions. (If you are using the z-wave controller, refer to the setup menu, association section). A note about dimming, if you combine Z-Wave enabled dimmers and other types of Z-Wave devices in a group, place a Z-Wave enabled dimmer into the empty group first to ensure that the dimming operates correctly. The Group4 name is wireless.(Profile MSB=0x20,Profile LSB=0x03)

Configuration

Configuration Parameter	Function	Size(Byte)	Value	Default
1	Night light	1	0-1	1
2	Memory function	1	0-1	1
3	Invert switch	1	0-1	0
4	LED Transmission indication	1	0-2	1
5	Suspend Group4	1	0-1	0

Night light

- Parameter NO:1
- Length: 1 Byte
- Valid values=0 or 1 (default value is 1)

The LED on the switch will by default, turn ON when the load attached is turn OFF. To make the LED turn ON when the load attached is turn ON instead, set parameter 1 to a value of 1.

Memory function

Parameter NO:2

- Length: 1 Byte
- Valid values=0 or 1 (default value is 1)

Stated in the above form, switch by default value is 1, when the value is 0, switch memory function not open; when the value is 1, open switch memory function.

Invert switch

- Parameter NO:3
- Length: 1 Byte
- Valid values=0 or 1 (default value is 0)

To change the top of the switch to OFF and the bottom of the switch ON, set parameter 3 to 1.

Note: if you invert the switches and also install the product upside down, remember the load will now be controlled by the right, not the left switch.

LED transmission indication

- Parameter NO:4
- Length: 1 Byte
- Valid values = 0,1,2,(default value is 1)

The switch will flicker its LED when it is transmitting to any of its 4 groups. This flickering can be set to not flicker at all (set to 0), to flicker the entire time it is transmitting (set to 2), or to flicker for only 1 second when it begins transmitting (set to 1). By default, the switch is set to flicker for only 1 second. Each configuration parameter can be set to its default setting by setting the default bit in the configuration set command. see your controller's instructions on how to do this (and if it supports it). All configuration commands will be reset to their default state when the switch is reset from the Z-Wave system.

Suspend group 4

- Parameter NO:5
- Length: 1 Byte
- Valid values = 0 or 1 (default value is 0)

You may wish to disable transmitting commands to Z-Wave devices that are in Group 4 without “disassociating” those devices from the group. Setting parameter 5 to the value of 1 will stop the switch from transmitting to devices that are “associated” into Group 4.

Power level

The switch supports the power level command.

The power level command allows controllers to set and get the RF transmit power level of a node and test specific links between nodes with specific RF transmit power. Refer to your controller’s instruction, if it supports this command, for more information. This command is typically used by professional installers.

Specification

Operating Voltage	AC230V 50Hz
Maximum Load	1380W×2
Range	Minimum 40m in door 70m outdoor line of sight
Operating Temperature	0°C ~ 40°C
Frequency Range	868.4MHz(EU),869MHz(RU)

Specifications are subject to change and improvement without notice.



Switch Size (mm)

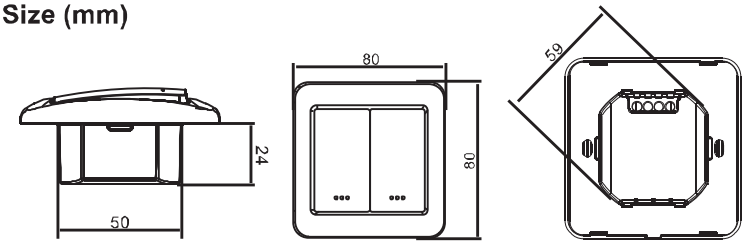

TZ37

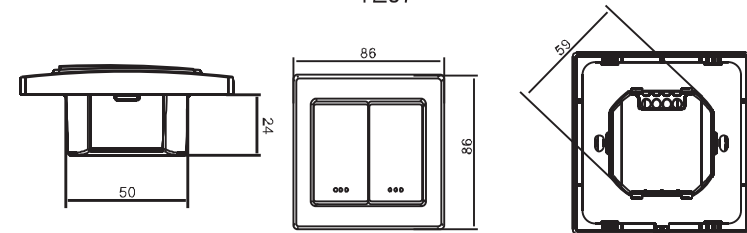

TZ57

Switch Type

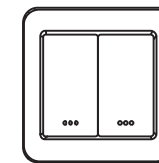

TZ37

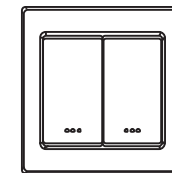

TZ57

TC series touch screen switch

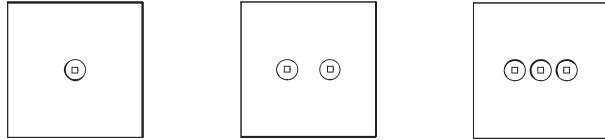

Note: This module must be “Included in the Network” only where it will be permanently installed. The proper operation of this node in the mesh network is dependent on knowing its location with respect to other nodes. You cannot “test bench” configure this module then install.

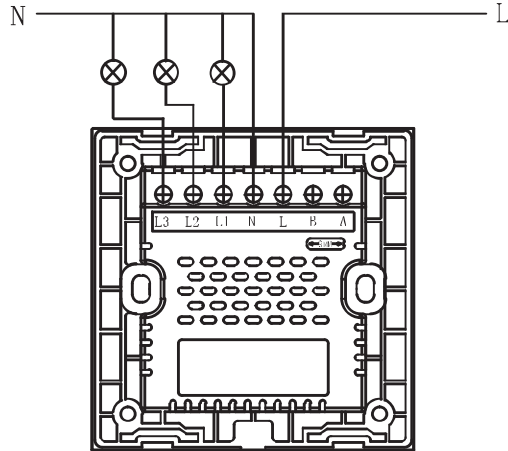

L: Line voltage input
L1,L2,L3: Switched load output
N: Line neutral

-20-

The touch switch is a component of the lighting control system. This Touch switch is designed to work with other Z-Wave enabled devices. Z-Wave nodes of other types can be added to the system and will also act as repeaters if they support this function of repeating the signal received to other modules in the system. As part of a Z-Wave network, this switch will also act as a wireless repeater to insure that commands intended for another device in the network are received. This is useful when the device would otherwise be out of the radio range of the wireless controller. There are no field repairable assemblies on this unit. If service was need, the unit must be returned where purchased.

Adding to Z-Wave™ Network

In the front casing, any of the touch button with LED indicator which is used to toggles witch on and off or carry out inclusion, exclusion, reset or association. When first power is applied, its LED flashes on and off alternately and repeatedly at 1-second intervals. It implies that it has not been assigned a node ID and cannot work with Z-Wave enabled devices. The table below lists an operation summary of basic Z-Wave function. Please refer to the instructions for your Z-Wave™ certificated primary controller to access the setup function, and to include/exclude/associate devices.

Function	Description	LED Indication
No node ID	The Z-Wave controller does not allocate a node ID to the Switch	1-second on, 1-second off
Add	1. Have Z-Wave controller entered inclusion mode. 2. Pressing On/Off button three times within 1.5 seconds will enter inclusion mode.	Press on, for off Press off, for on
Remove	1. Have Z-Wave controller entered inclusion mode. 2. Pressing On/Off button three times within 1.5 seconds will enter exclusion mode.	Press on, for off Press off, for on

-21-

Function	Description	LED Indication
	Node ID has been excluded.	1-second on, 1-second off
Reset	1. Pressing On/Off button three times within 1.5 seconds will enter inclusion mode.	Press on, for on Press off, for off
	2. Within 5 second, press On/Off button again for 1 seconds until LED is off	
	3. IDs are excluded.	
Association	1. Have Z-Wave Controller entered association mode. Or Pressing On/Off button three times within 1.5 seconds will enter association mode	Press on, for on Press off, for off
	2. There is one group for the switch (it can associate max five devices).	

- ※ Including a node ID allocated by Z-Wave controller means Add. Excluding a node ID allocated by Z-Wave controller means Remove.
- ※ Failed or success in including/excluding the node ID can be viewed from the Z-Wave controller.
- ※ Association: it can be associated by Z-Wave devices with association
- ※ Use the "Reset" procedure only in the event that the network primary controller is missing or otherwise inoperable
- ※ The group identifier: "Group 1".
Association group info report command class
Group Profile: General Lifeline (Profile MSB = 0, Profile LSB = 1)
Group name: Lifeline

Basic Operation (Local Control)

The touch sensor on the switch allows the user to:

-Turn on or off the attached load.

-Include or exclude the module from the Z-Wave system.

Also, when a controller prompts you to "Send Node ID" or to "Press Button on Unit", quickly tap the touch sensor three times to satisfy those instructions.

LED Indication

The LED under the touch sensor will turn on when the load attached is off, to act as a night light. Otherwise, it will turn off when the load attached is On.

Power level

The switch supports the power level command.

The power level command allows controllers to set and get the RF transmit power level of a node and test specific links between nodes with specific RF transmit power. Refer to your controller's instruction, if it supports this command, for more information. This command is typically used by professional installers.

Supported Command Class

COMMAND_CLASS_VERSION
COMMAND_CLASS_ASSOCIATION_V2
COMMAND_CLASS_MANUFACTURER_SPECIFIC_V2
COMMAND_CLASS_BASIC
COMMAND_CLASS_SWITCH_BINARY
COMMAND_CLASS_DEVICE_RESET_LOCALLY
COMMAND_CLASS_MULTI_CHANNEL_V3 (For the TC1021 TC1031)
COMMAND_CLASS_FIRMWARE_UPDATE_MD_V2 (Support the OTA update)



Panel Color

Support the panel color of gold, gray, red, white, black

Specification

Type	Support the dimming	Number of supported channels	Maximum Load
TC1011	NO	1	5A one channel, 10A All of the channels
TC1021	NO	2	
TC1031	NO	3	

Operating Voltage	AC230V 50Hz
Range	Minimum 40m in door 70m outdoor line of sight
Operating Temperature	0°C~40°C
Frequency Range	868.4MHz(EU),869MHz(RU)

Specifications subject to change without notice due to continuing product.



Switch Size(mm)

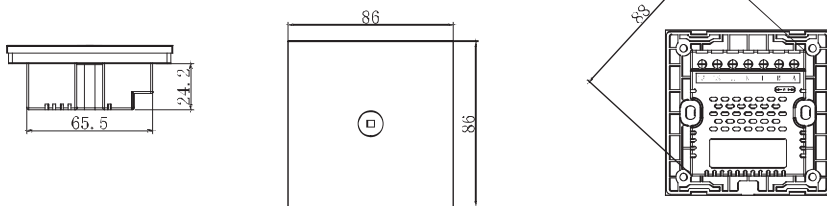

Switch Type

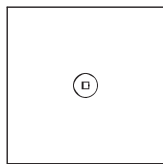

TC1011

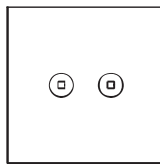

TC1021

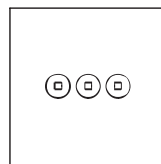

TC1031

TC10X1-V1.0-20170418